



**CITY OF SAN JOSE**  
**BUILDING DIVISION POLICY**

---

**Policy on Water Heater Installations**

**Policy No. UPC 510-1-94**  
**Effective: September 1, 1995**  
**Revised: February 10, 1996**

---

All new and replacement water heaters installed in the City of San Jose shall be installed in compliance with the latest edition of the Uniform Plumbing Code (UPC) regarding elevation and bracing.

1. UPC Section 1310(a) requires that the pilot light, burner, heating elements, or any other portion of a water heater which could serve as a source of ignition of flammable vapors be elevated at least 18" above floor level when installed in garages.
2. Water heaters installed in the potential path of vehicle traffic shall be considered protected from damage as required by UPC 1310(c) if installed on a platform which is 18" or more above the floor level.
3. All new or replacement water heaters shall be braced in compliance with the standard details related to seismic bracing which have been established by the State of California, Division of the State Architect (see attached).

Initiated by:  
Phillip H. Ribbs, Chief  
Plumbing/Mechanical/Electrical Inspector  
Barry Keech, Supervising  
Plumbing/Mechanical Inspector  
Ron Cabral,  
Building Inspector/Combination

Approved by:  
  
Chief Building Official

---

---

# Earthquake Bracing of Water Heaters for Single-Family Home

---

---

January 1993

*STATE AND CONSUMER SERVICES AGENCY  
DEPARTMENT OF GENERAL SERVICES  
OFFICE OF THE STATE ARCHITECT*

*HARRY C. HALLENBECK, FAIA  
STATE ARCHITECT*

## INTRODUCTION

Experience has shown that water heaters can move or tip over during an earthquake if not properly anchored to the walls. Movement of or impact to the water heater may cause gas leaks in gas line connections, which in turn may pose a fire hazard. Water leaks from broken water lines may also cause water damage to floors and walls.

Because of the recognized potential for damage, Assembly Bill (AB) 1890 (Cortese) was introduced and ultimately passed into law as Chapter 951, Statutes of 1989, on September 27, 1989. The bill adds Article 8 (commencing with Section 19210) to Chapter 2 of Part 3 of Division 13 of the Health and Safety Code.

AB 1890 requires all new and replacement water heaters sold in California on or after July 1, 1991, to be braced, anchored, or strapped to resist falling or horizontal displacement due to earthquake motion. The new law also requires all water heaters manufactured for sale in California on or after July 1, 1991, to include a statement in the installation instructions that water heater units must be braced, anchored, or strapped to resist falling or horizontal displacement due to earthquake motion. Manufacturers of water heaters must add language to current instruction labels which discloses the danger of falling or horizontal displacement due to an earthquake and the Office of the State Architect (OSA) must prepare generic installation instructions with standard details illustrating the strapping, bracing and anchoring of water heaters for typical installations in single-family homes. These instructions must comply with specified requirements and must be available for reproduction by appliance retailers.

Retailers are also permitted to provide the consumer with generic installation instructions with standard details. If provided, these generic instructions are intended as a guide to the consumer, and are not to supersede local codes. The public utilities, retailers, and manufacturers are not liable for the generic instructions provided to consumers as long as they have been approved by OSA, as complying with the requirements of the model codes in force on the date of approval.

The following instructions and details were prepared and approved by OSA for water heaters up to and including the 52 gallon size. The 52 gallon size is the largest typical size that was readily available for residential use. Larger heaters will require additional bracing, in proportion to their sizes to a 52 gallon tank (i.e. 75 gallon would require 3 sets; 100 gallon would require 4 sets).

Most water heaters should be provided with at least 1" of clearance from the wall unless rated otherwise. Check with your local building department for clearances required in your area. It is suggested that semi-rigid gas connectors (i.e. aluminum or copper tubing) should be replaced with approved flexible connectors of adequate length. The water connection should also be made with an approved flexible connection.

These bracing methods comply with the 1991 Uniform Building Code.

## **METHODS OF EARTHQUAKE BRACING OF WATER HEATERS FOR RESIDENTIAL USE**

In this manual there are two distinct methods of bracing water heaters. They can best be described as the Tape Method which uses only plumbers tape with bolts, lag screws and some other materials, and the Conduit Method, which uses round thin wall conduit along with plumbers tape, bolts, and lag screws.

### Tape Method

The first, and perhaps simplest method presented for bracing of water heaters is using the tape method. Required materials and tools are listed adjacent to the drawing for that installation.

#### Helpful Hints:

- A simple method for locating studs behind the wall finish is to use a very small drill bit to drill a series of holes in the finish until the stud is located. Both sides of the stud should be located in order to place the pilot hole for the lag screws in the approximate center of the stud. A commercial stud finder can also be purchased from your local hardware store to locate studs.
- Screwing the lag screw into the hole can best be accomplished with the use of a 7/16" socket with ratchet handle. Do not drive with hammer.
- It is possible that a 10' length of plumber's tape will not be long enough for this installation. If this proves to be the case, the plumber's tape can be spliced using a 1/4" hex head bolt or 1/4" round head machine screw with washers on each side and a nut.

### Conduit Method

The second method presented for installation utilizes conduit, and looks more professional and attractive than the tape method. Required materials and tools are listed adjacent to the drawing for that installation.

#### Helpful Hints:

- A vise is the simplest method for flattening the ends of the conduit. A hammer and any hard, flat surface will also work for flattening the conduit, but is more cumbersome and less attractive.
- Using the 1/4" x 1" hex head bolts makes it easier to draw up the plumber's tape around the water tank using a 7/16" socket, extension and ratchet handle.

**INSTRUCTIONS FOR INSTALLING A WATER HEATER RESTRAINT  
FOR CORNER PLACEMENT OF WATER HEATER USING TAPE METHOD**

1. Mark water heater 9" down from the top and approximately 4" up from the top of the controls.
2. Using a stud finder or another appropriate method, locate the closet wall stud not directly behind the water heater (see attached detail for illustration). Position of the water tank with respect to the location of the support studs is important. Stretch a string between the support studs and determine if distance to the face of the tank meets the requirements shown in the sketch. If it does not it may be necessary to empty the tank and move it if it has flexible water and gas connections or if not moveable the locations of support can be moved using the detail on page 11.
3. Transfer marks on the water heater horizontally to the adjacent wall where the stud identified in step 2 was located.
4. Drill a 3/16" diameter pilot hole in the marked studs at least 3" deep.
5. Anchor one end of the tape to the wall with 1/4" diameter lag screw and wrap tape around tank and pull tight to anchor stud on the opposite wall.
6. Mark point for hole in opposite wall and drill pilot hole.
7. Cut off tape and install lag screw with washers. It is important that the tape be tightly stretched. If the tape is not tight, remove the lag screw and place it in the next 1/4" hole in the tape and tighten.
8. Repeat as necessary for all pieces of tape required (See Page 4).

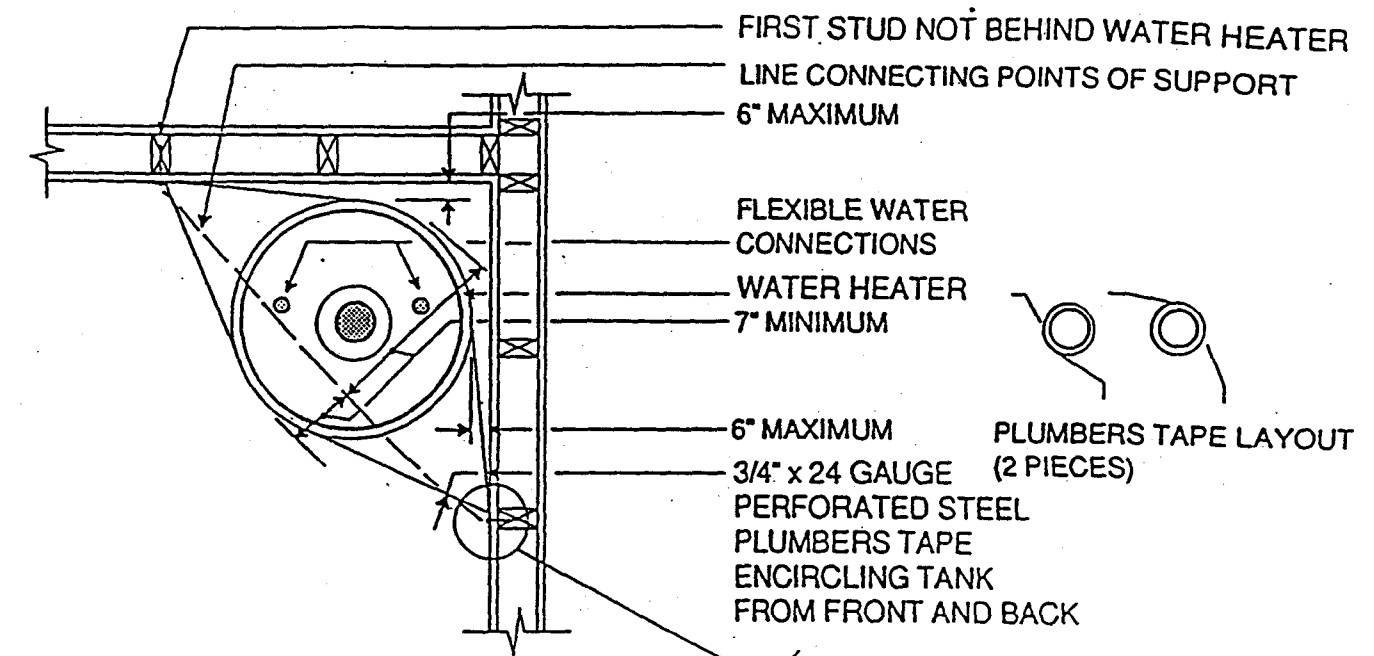

PLAN

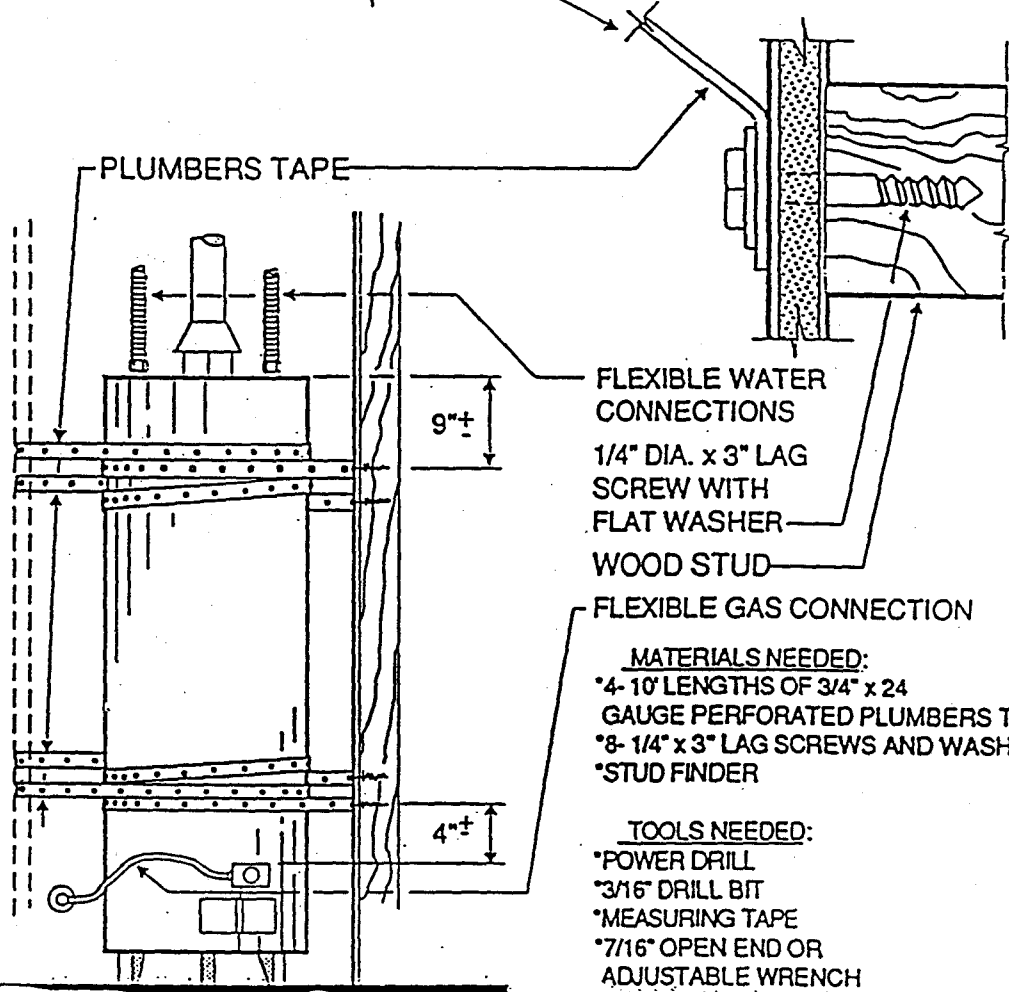

ELEVATION

WATER HEATER IN CORNER

## **INSTRUCTIONS FOR INSTALLING A WATER HEATER RESTRAINT FOR STRAIGHT WALL PLACEMENT OF WATER HEATER USING TAPE METHOD**

(This method requires that the tank be at least 2 1/2" from the wall. It may be necessary to move the tank to use this method. The water tank can be fairly easily moved if empty and water and gas are connected with flexible connections.)

1. Mark water heater 9" down from the top and approximately 4" up from the top of the controls. Transfer these marks to the wall. (See Page 6).
2. Using a stud finder or another appropriate method, locate the studs to receive the wood 2 x 4 ledger at the heights marked on the wall.
3. Measure the distance between the center line of the studs which are going to support the 2 x 4, add 4", and cut off 2 x 4 to this length.
4. Drill a 1/4" diameter hole in the cut off 2 x 4, 2" in from each end and about the center of 4" dimension. (The 4" dimension is a nominal dimension and is approximately 3 1/2".)
5. Hold the 2 x 4 on the wall at the correct height lining up the 1/4" hole over the center of the wall studs. Through the 1/4" hole, drill a 3/16" diameter hole in the stud as deep as the bit will permit. A 3/16" bit is approximately 3 1/2" long with approximately 1/2" taken up in the part of the drill that holds the bit. Remove the 2x4 from the wall and drill hole to full depth.
6. Place the 2 x 4 on the wall and insert the 1/4" diameter by 5" lag screws through the holes in the 2 x 4 and insert them into the 3/16" holes in the wall. Tighten the screws only enough to hold the 2 x 4 in place as the 2 x 4 will have to be taken down to drill the holes in the top of the 2 x 4 for the connection of the plumbers tape. There is not enough room for the drill when the 2x4 is attached to the wall.
7. Mark the appropriate locations for connection of the tape and measure the distance from the face of the 2 x 4 to the face of the tank. Remove the 2 x 4 from the wall. Drill the 3/16" diameter holes in the top of the 2 x 4. On the face of the 2 x 4, where the tank occurs, place the required thickness of gypsum wallboard (drywall)(fire resistant). The tank must fit up against the drywall when the 2 x 4 is in place against the wall. A piece of wood 3 1/2" wide and the thickness needed to obtain the proper fit against the tank may be used next to the 2 x 4. At least 1" thickness of drywall must be installed. The drywall can be attached to the 2 x 4 with nails, but the nails must penetrate the wood by at least 1". The dry-wall can also be attached by tying it in place with 24 gauge wire.
8. Place 2 x 4 behind the tank and place 1/4" x 5" lag with washer in the ends of the 2 x 4 and tighten. Measure distance from one of the holes in the top of the 2 x 4 around the tank and back to the same hole, then add 2". Cut a length of plumbers tape to this dimension. Place the cut length of plumbers tape and attach to the top of the 2 x 4 with a 1/4" x 3" lag screw with washer through both ends of the tape. Repeat the process for the other hole in the top of the 2 x 4.
9. Repeat the process for the other 2 x 4 and taping. (See Page 6).

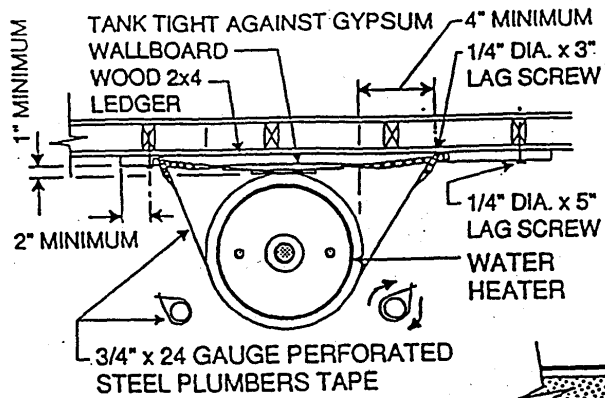

- MATERIALS NEEDED:**
- \*GYPSUM WALLBOARD (FIRE RESISTANT DRYWALL)
  - \*24 GAUGE WIRE
  - \*2- 2x4 x 4'-0" TO 6'-0" LONG
  - \*4- 10' LENGTHS 3/4" x 24 GAUGE PERFORATED PLUMBERS TAPE
  - \*4- 1/4" x 5" LAG SCREWS
  - \*4- 1/4" x 3" LAG SCREWS

- TOOLS NEEDED:**
- \*POWER DRILL
  - \*1- 1/4" DRILL BIT
  - \*1- 3/16" DRILL BIT
  - \*STUD FINDER
  - \*MEASURING TAPE
  - \*7/16" OPEN END OR ADJUSTABLE WRENCH

PLAN

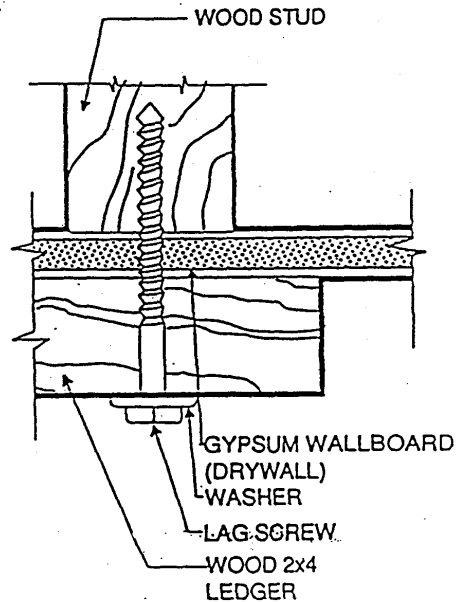
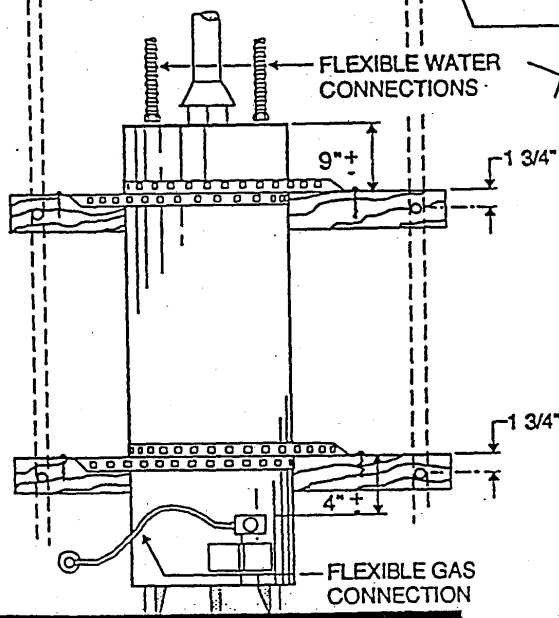
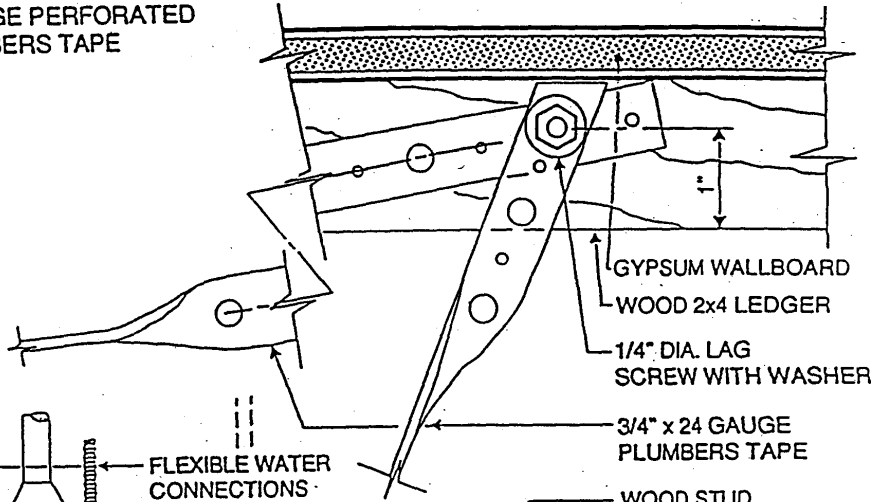

ELEVATION

WATER HEATER ON STRAIGHT WALL



## **INSTRUCTIONS FOR INSTALLING A WATER HEATER RESTRAINT FOR WATER HEATER ON STRAIGHT WALL USING CONDUIT METHOD**

1. Mark water heater 9" from top and approximately 4" up from the top of the controls. Transfer these marks to the wall. Locate wood studs in the wall on both sides of the water heater (See Page 8).
2. Using a stud finder or another appropriate method, locate the closest wall stud not directly behind the water heater (See attached detail for illustration).
3. Transfer marks on the water heater horizontally to the adjacent wall where the stud identified in step 2 was located.
4. Drill a 3/16" diameter, 3" deep pilot hole at the locations for the 1/4" diameter by 3" lag screws.
5. Measure around the water tank and add 2" to the measurement. Cut two pieces of 3/4" x 24 gauge perforated steel plumbers tape to this length. Place a bolt with washer through end hole of one end and bend out 90 degrees as close to the edge of the washer as possible. Most plumbers tape comes with 1/4" diameter holes 1" apart with 1/8" diameter holes in between. The tape can be easily broken at the smaller holes by grabbing the tape with pliers and bending several times.
6. Place tape around tank and place bolt with washer through the nearest hole in the end of the tape, place a washer and nut on the bolt and tighten. The tape should be tight. If the tape is not tight, remove the bolt, place it through the next adjacent 1/4" diameter hole and tighten.
7. Using a measuring tape, measure the distance from the hole in the stud to a point on the tape, which is tangent or almost tangent to the tank, at one of the holes in the tape. Add 1" to these measurements and cut 1/2" diameter conduit to this length. Repeat this for each piece of conduit.
8. Using a hammer or vice, flatten 1" at each end of the 4 pieces. Be sure to flatten both ends of the conduit in the same plane.
9. Drill a hole in one end of each conduit approximately 1/2" from each end. Measure 1" in from each end and bend up at approximately 45 degrees. This angle will have to be corrected slightly as the work progresses. Hold conduit on the wall with the hole in the conduit over the hole in the wall, and mark the other end at one of the holes in the plumbers tape. Mark holes in the tape and on the tank and conduit. Take down conduit and a hole at the mark for the bolt through the flattened end of the conduit. Repeat for the conduit on the other side.
10. Loosen strap around the tank and place a bolt with washer from the inside through the holes in the tape at all locations. Tighten the tape around the tank so that the bolts are at the marks on the tank. It may be easier to do one side of the tank at a time, as positioning of the tape can be difficult. Place conduit on bolt protruding from the strap and place a washer and nut on the bolt and tighten. (A 4d finish nail inserted in the slot in the bolt will prevent the head from turning.) Position the opposite end at the hole in the wall and insert lag screw with washer and tighten. Do not drive lag screw with hammer.
11. Repeat the above procedure for the rest of the conduits. (See Page 8).
12. See Page 11 for alternate where stud locations do not meet limitations shown on Page 8.

NOTE: The 1/4" x 1" bolts referred to above are called 1/4" x 1" round head machine screws with nut at the hardware store.

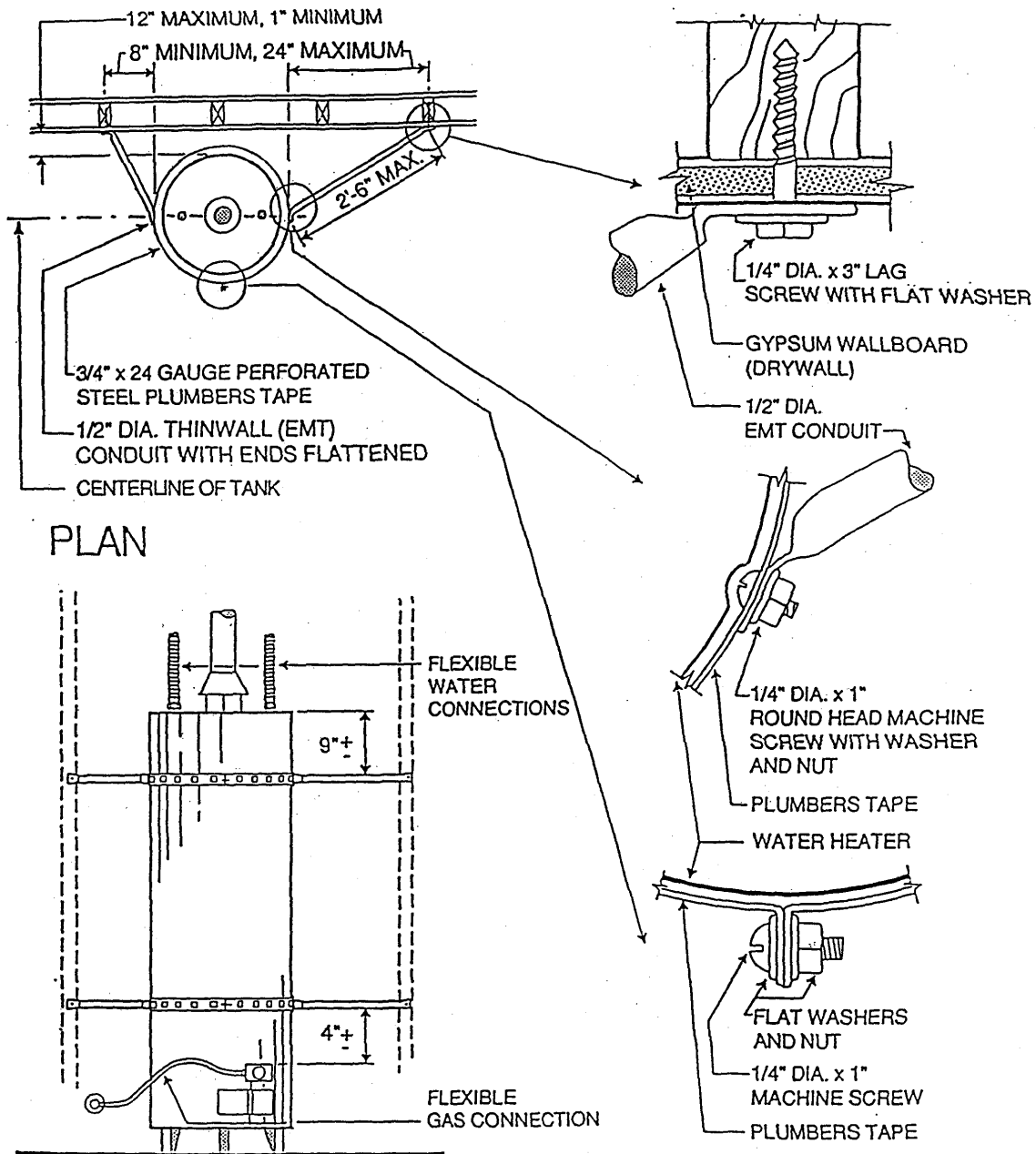

ELEVATION

SEE PAGE 10 FOR MATERIALS AND TOOLS

WATER HEATER ON STRAIGHT WALL

## **INSTRUCTIONS FOR INSTALLING A WATER HEATER RESTRAINT FOR CORNER PLACEMENT OF WATER HEATER USING CONDUIT METHOD**

1. Mark water heater 9" down from top and approximately 4" up from the top of the controls. Transfer these marks to the wall. Locate wood studs in the wall on both sides of the water heater (See Page 10).
2. Using a stud finder or another appropriate method, locate the wall studs that meet the minimum and maximum criteria shown on page 10. (See attached detail for illustration).
3. Transfer marks on the water heater horizontally to the adjacent wall where the stud identified in step 2 was located.
4. Drill a 3/16" diameter, 3" deep pilot hole at the locations for the 1/4" diameter by 3 1/2" lag screws.
5. Measure around the water tank and add 2" to the measurement. Cut two pieces of 3/4", x 24 gauge perforated steel plumbers tape to this length. Place a bolt with washer through end hole of one end and bend out 90 degrees as close to the edge of the washer as possible. Most plumbers tape comes with 1/4" diameter holes 1" apart with 1/8" diameter holes in between. The tape can be easily broken at the smaller holes by grabbing the tape with pliers and bending several times.
6. Place tape around tank and place bolt with washer through the nearest hole in the end of the tape, place a washer and nut on the bolt and tighten. The tape should be tight. If the tape is not tight, remove the bolt, place it through the next adjacent 1/4" diameter hole and tighten.
7. Using a measuring tape, measure the distance from the hole in the stud to a point on the tape, which is tangent or almost tangent to the tank at one of the holes in the tape. Add 1" to these measurements and cut 1/2" diameter conduit to this length. Repeat this for each piece of conduit.
8. Using a hammer or vice, flatten 1" at each end of the 4 pieces. Be sure to flatten both ends of the conduit in the same plane.
9. Drill a hole in one end of each conduit approximately 1/2" from each end. Measure 1" in from each end and bend up at approximately 45 degrees. This angle will have to be corrected slightly as the work progresses. Hold conduit on the wall with the hole in the conduit over the hole in the wall, and mark the other end at one of the holes in the plumbers tape. Mark holes in the tape and on the tank and conduit. Take down conduit and drill a hole at the mark for the bolt through the flattened end of the conduit. Repeat for all other pieces of conduit.
10. Loosen strap around the tank and place a bolt with washer from the inside through the hole in strap at all four locations. Tighten the tape around the tank so that the bolts are at the marks on the tank. It may be easier to do one side of the tank at a time, as positioning of the tape can be difficult. Place conduit on bolt protruding from the strap and place a washer and nut on the bolt and tighten. (A 4d finish nail inserted in the slot in the bolt will prevent the head from turning.) Position the opposite end at the hole in the wall and insert lag screw with washer and tighten. Do not drive lag screw with hammer.
11. Repeat the above procedure for the rest of the conduits. (See Page 10).

NOTE: The 1/4" x 1" bolts referred to above are called 1/4" x 1" round head machine screws with nut at the hardware store.

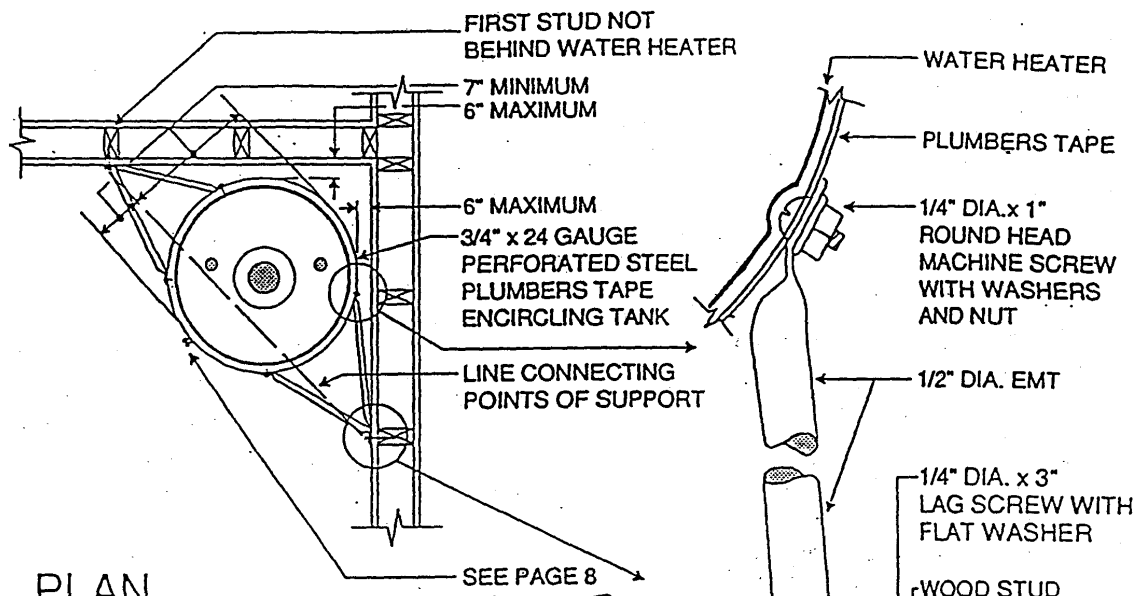

PLAN

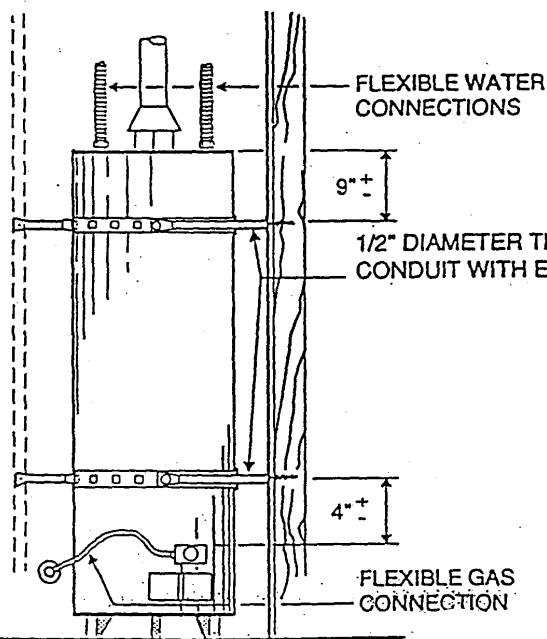

ELEVATION

WATER HEATER IN CORNER

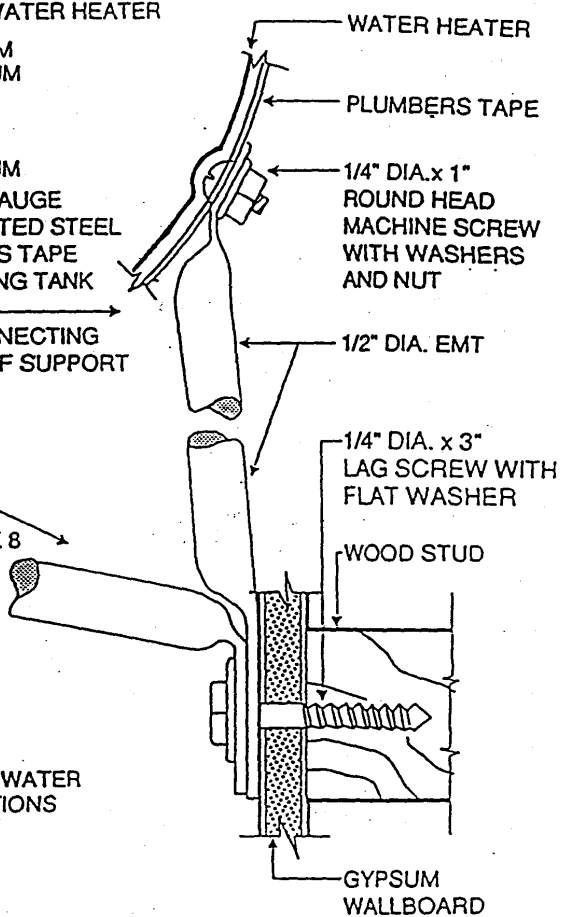

**MATERIALS NEEDED:**

- \*12'-3/4" x 24 GAUGE PERFORATED PLUMBERS TAPE
- \*2- 10' LENGTHS 1/2" DIA. EMT CONDUIT
- \*8- 1/4" DIA. x 1" ROUND HEAD MACHINE SCREWS
- \*12- 1/4" WASHERS
- \*16- 1/4" NUTS
- \*4-1/4" DIA. x 3" LAG SCREWS

**TOOLS NEEDED:**

- \*TAPF MEASURE
- \*HAMMER
- \*HACK SAW
- \*CENTER PUNCH
- \*STUD FINDER
- \*POWER DRILL
- \*1/4" DIA. DRILL BIT
- \*3/16" DIA. DRILL BIT
- \*7/16" OPEN END OR ADJUSTABLE WRENCH

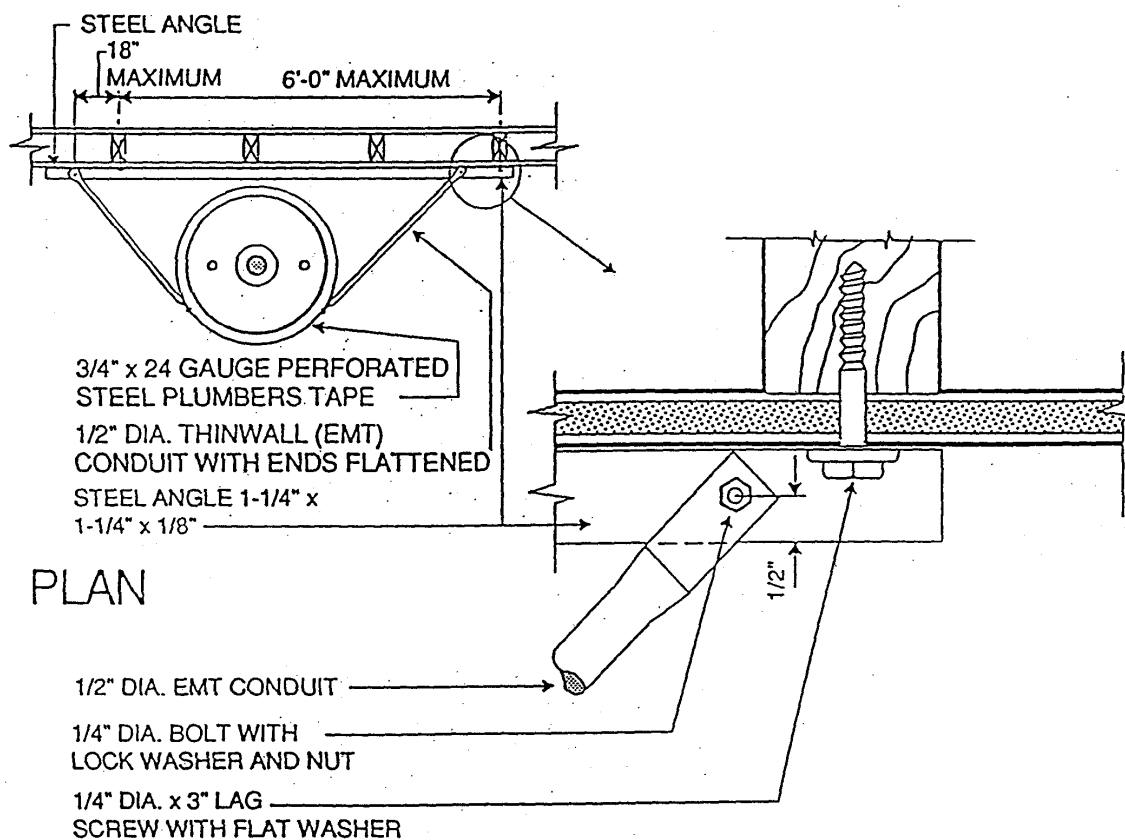

ALTERNATE WHERE STUD LOCATIONS DO NOT MEET LIMITATIONS

## **INSTRUCTIONS FOR INSTALLING A WATER HEATER RESTRAINT ON A CONCRETE, HOLLOW CONCRETE BLOCK, OR BRICK WALL**

1. Use a 1/4" diameter Hilti, Phillips Red Head Sleeve Anchor, or equal having a minimum embedment of 1 1/8".
2. Using a 1/4" masonry bit, drill a hole to any depth greater than the minimum depth.
3. Insert the assembled anchor into the hole through the tape or flattened tube, so that the assembly is tight against the wall.
4. Expand the anchor by tightening the nut 2-to-3 turns. The wall must be sound, without cracks, and be able to withstand a load of 180 pounds. Some brick are relatively soft and cannot be used for this purpose. It may be necessary for an architect or engineer to, determine if the wall is suitable for anchorage. Do not place the anchor closer than 2" from the end of the wall.

### **INSULATION-WRAPPED TANKS**

Any preexisting insulation around the outside of the tank should be removed and replaced after the restraints are installed.

### **TANKS ON PLATFORMS**

Tanks installed in garages and other locations are often placed on platforms which are approximately 18" above the floor. A check should be made to ensure the platform is anchored to the floor or walls of the structure.

1310 - Item Number 1

**SUBJECT: REPLACEMENT OF WATER HEATERS IN GARAGES**

**SECTION:** 1310

**REFERENCE:** Uniform Plumbing Code, 1991 Edition

**LAST REVIEW:** 1993 IAPMO Code Interpretations Committee

**QUESTION:** Does replacement of an existing fuel-burning water heater in a residential garage necessitate conformity with the current requirements of Section 1310?

**ANSWER:** Yes, due to the potential hazard created by the installation of the water heater in this location, replacement water heaters must be elevated to meet the requirements of Section 1310. Additionally, the water heater may need to be anchored or strapped to meet the requirements of Section 1310(e) and be protected from mechanical damage.

Uniform Plumbing Code Interpretations Manual

1310(a) - Item Number 1

**SUBJECT: ELEVATING WATER HEATERS IN GARAGES**

**SECTION:** 1310(a)

**REFERENCE:** Uniform Plumbing Code, 1991 Edition

**LAST REVIEW:** 1993 IAPMO Code Interpretations Committee

**QUESTION:** Are all electric water heaters required to have the heating elements and thermostats (switches) elevated to a minimum of 18 inches above the floor level when installed in a residential garage?

**ANSWER:** It is the opinion of the Code Interpretations Committee that Section 1310(a) includes both gas and electric water heaters. The wording of the section "heating elements and switches" does cover the possibility of a spark or glow from an electric water heater. The spark from a switch, thermostat, or heat from a heating element is as capable of igniting flammable vapors as a standing pilot flame or burner.